

TEAC

SERVICE MANUAL

20" COLOUR TELEVISION

MODEL: CT-M480

SKYWORTH ELECTRONICS CO., LTD

CTV-8148GP

CTV-8208GP

(T-M48)

SAFETY TEST AND ALIGNMENT INSTRUCTION

FOR : PAL/BG W/FTZ

PREPARED BY : *T. Y. Que*
APPROVED BY : *T. Y. Que*
DATE : 3 DEC 1993
REVISION DATE :

X-RAY RADIATION PRECAUTION

- 1) Excessive high voltage can produce potentially hazardous X-Ray Radiation. To avoid such hazards, the high voltage must not be above the specified limit. The normal value of the high voltage of this receiver is 26KV at zero beam current (minimum brightness) under 220V AC power source. The high voltage must not, under any circumstances, exceed 28KV.
- 2) Each time a receiver requires servicing, the high voltage should be checked following the High Voltage Check procedure in this manual. It is recommended the reading of the high voltage be recorded as a part of the service record. It is important to use an accurate and reliable high voltage meter.
- 3) The primary source of X-Ray Radiation in this TV Receiver is the picture tube. For continued X-Ray Radiation protection, the replacement tube must be exactly the same type tube as specified in the parts list.
- 4) Some parts in this receiver have special safety - related characteristics for X-Ray Radiation protection. For continued safety, parts replacement should be undertaken only after referring to the Product Safety Notice.

SAFETY PRECAUTION

Warning : Service should not be attempted by anyone unfamiliar with the necessary precautions on this receiver.

The following are the necessary precautions to be observed before servicing this chassis.

- 1) Since the power supply circuit of this receiver is directly connected to the AC power line, an isolation transformer should be used during any dynamic service to avoid possible shock hazard.
- 2) Always discharge the picture tube anode to the CRT conductive coating before handling the picture tube. The picture tube is highly evacuated and if broken, glass fragments will be violently expelled. Use shatter proof goggles and keep picture tube away from the unprotected body while handling.
- 3) When replacing a chassis in the cabinet, always be certain that all the protective devices are put back in place, such as : non-metallic control knobs, insulating covers, shields, isolation resistor-capacitor network etc.
- 4) When replacing parts or circuit boards, disconnect the power cord.
- 5) When replacing a high wattage resistor (Metal oxide film resistor) on circuit board, keep the resistor 10mm (1/2 in.) away from circuit board.
- 6) Connection wires must be kept away from components with high voltage or high temperature.
- 7) If any fuse in this TV receiver is blown, replace it with the FUSE specified in the chassis parts list.
- 8) The receiver is designed to operate with 220V (50Hz) AC mains.

PRODUCT SAFETY NOTICE

Many electrical and mechanical parts in this chassis have special safety-related characteristics. These characteristics are often passed unnoticed by a visual inspection and the X-Ray Radiation protection afforded by them cannot necessarily be obtained by using replacement components rated for high wattage, etc. Replacement parts which have these special safety characteristics are identified in this manual and its supplements, electrical components having such features are shaded on the schematic diagram and the part list.

Before replacing any of these components, read the parts list in this manual carefully. The use of substitute replacement parts which do not have the same safety characteristics as specified in the parts list may create shock, fire, X-Ray Radiation or other hazards.

GENERAL ADJUSTMENT INSTRUCTION

This receiver is transistorized and special care should be taken when servicing. Read the following matters that demand special attention before attempting adjustment.

- 1) Adjustment requires an exact procedure and should be undertaken only when necessary.
- 2) An isolation transformer should be used during any dynamic service to avoid possible shock hazard.
- 3) The test equipment specified or its equivalent is required to perform the alignment properly. Use of equipment which does not meet these requirements may result in improper alignment.
- 4) Correct matching of the equipment is essential. Failure to use proper matching will result in responses which can not represent the true operation of the receiver.
- 5) The AC power line voltage should be kept 215 to 235 volts 50Hz during alignment.
- 6) Do not attempt to connect or disconnect any wire while the receiver is in operation. Make sure the power cord is disconnected before replacing parts in the receiver.
- 7) Unless otherwise noted, do not perform any adjustment until the receiver has been turned on for at least 10 minutes.

ALIGNMENT INSTRUCTION

A. PLEASE READ BEFORE ATTEMPTING SERVICE

- 1) Do not connect any antenna plug directly to the tuner socket and do not connect any equipments directly to the TV chassis, otherwise it may be burnt out the TV or equipment, except an isolation transformer is used for main power source of the TV sets.
- 2) Never disconnect any leads while receiver is in operation.
- 3) Disconnect all power before attempting any repairs.
- 4) Do not short any portion of the circuit while power is on.
- 5) For safety reasons, all parts replaced should be identical, (for parts and part numbers see parts list).
- 6) Before alignment the set must be pre-heated for 30 minutes or more and erase magnetism thoroughly from CRT front chassis frame by erase coil.

B. TEST EQUIPMENT

- 1) VIF Sweep Generator
- 2) AM/FM Signal Generator
- 3) DC Power Supply (16V)
- 4) Oscilloscope
- 5) Volt meter
- 6) High Voltage Meter
- 7) Demagnetizing Coil
- 8) Philips Pattern Generator
- 9) Audio Generator

C. PICTURE I. F. ALIGNMENT

- 1) Set sweep generator marker to 31.9MHz, 33.4MHz, 34.47MHz, 37.9MHz, 38.9MHz, 40.4MHz, modulation output level 60dB.
- 2) Connect the signal output of Sweep/Marker Generator to the TP101 (Pin 5 of IC101) through 1000PF capacitor.
- 3) Connect the vertical input terminal of Sync Oscilloscope in series with a 100K Ohm resistor to TP102 (Pin 18 of IC101).
- 4) Apply a +16V DC across C320.
- 5) Apply a +3.5V DC dummy AGC bias to TP103 (Pin 24 of IC101). As shown in Fig 1.
- 6) Adjust L106 to obtain maximum amplitude of response at 38.9MHz as shown in Fig 2.

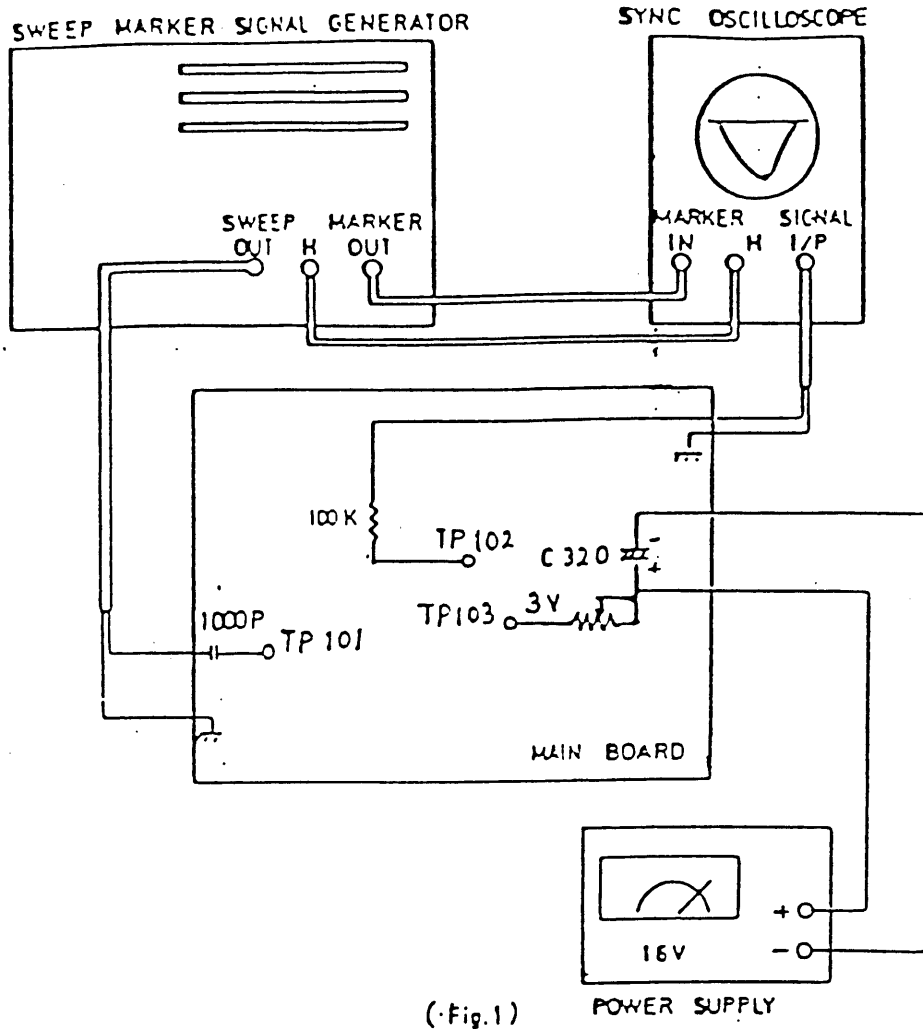

(Fig.1)

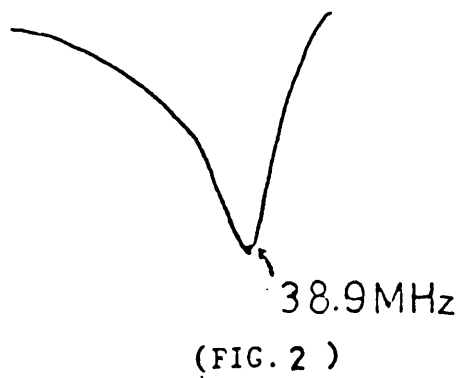

D. AFC ALIGNMENT

- 1) Reconnect the vertical input of the Oscilloscope to TP104 (Pin 19 of IC101) and between 10K OHM resistor to ground.
- 2) Set the Oscilloscope maximum.
- 3) Adjust L107 for waveform as shown in Fig 3.

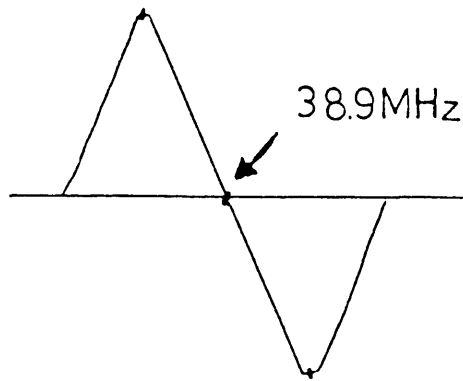

(FIG.3)

E. SIF ALIGNMENT

- 1) Set FM signal generator to 5.5MHz with AF 400Hz, 25KHz FM modulation output level 90-120dB. Apply this signal to TP105 through a 1000PF capacitor.
- 2) Short AGC TP103 (Pin 24 of IC101) and TP107 (Q110 "B") to Ground.
- 3) Connect the Oscilloscope input in series with a 100k Ohm resistor to TP106 (Pin 11 of IC101).
- 4) Apply a +16V DC across C320 as shown in Fig 4.
- 5) Adjust L112 to obtain a maximum amplitude signal output with minimum distortion.

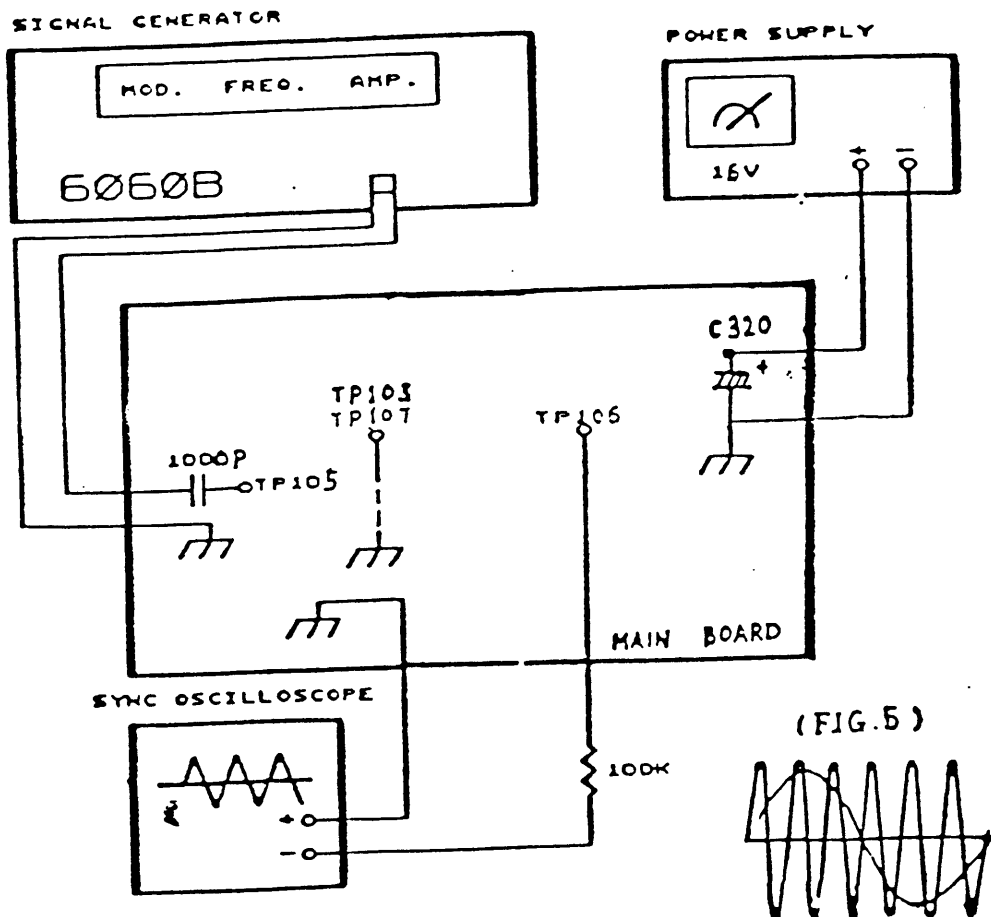

(FIG. 4)

F. 30.9MHz AND 40.4MHz TRAPS ALIGNMENT

- 1) Connect the signal output of Sweep/Market Generator to the PIF output of tuner through 1000PF capacitor.
- 2) Signal output set to 100dB.
- 3) Connect the oscilloscope as shown as below.
- 4) Apply a +16V DC to C320 (Main P.C.B)
- 5) Turn L102 for 30.9MHz.
- 6) Turn L101 for 40.4MHz as shown as below.

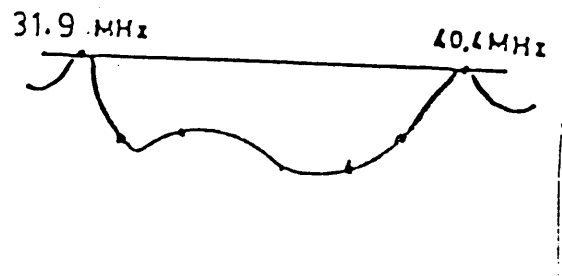
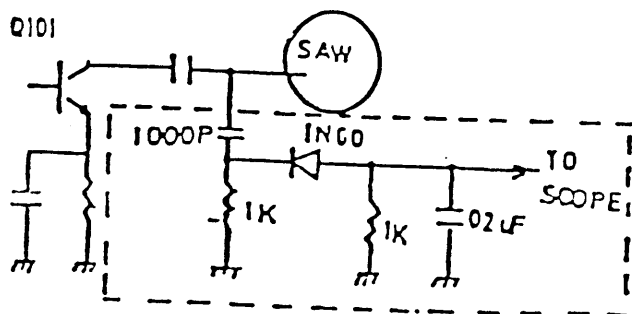

GENERAL ADJUSTMENT

AUTOMATIC DEGAUSSING

- 1) An automatic degaussing coil is attached around the picture tube, degaussing the tube properly in about one second after the set is switched on. If the receiver is moved or faced in a different direction, the power must be switched off at least 15 minutes in order that the automatic degaussing circuit operates properly. External degaussing is necessary if the automatic degaussing proves ineffective after the set is moved. External degaussing is done by moving a degaussing coil circlewise in front of the face plate and then moving it away step by step until it is about two meters from the screen, then switch off the degaussing coil. If residual color spots are still found on the screen, adjust the color purity and convergence.

B + ADJUSTMENT

CAUTION : To avoid X-Ray hazards, B + voltage must be set correctly at 110V position.

Make sure the AC Power Supply is 220V, 50Hz.

- 2) Switch on the TV receiver, tune in an active channel and adjust brightness/contrast for maximum.
- 3) Adjust VR601 check the B+ voltage, 110V AT C321 with a reliable DC voltmeter.

HIGH VOLTAGE CHECK

CAUTION : There is no high voltage adjustment in this chassis, B + voltage directly relates to the high voltage, it must be properly adjusted to insure the correct high voltage. The high voltage must not exceed 28Kv under any conditions.

- 1) Connect an accurate high voltage meter to the second anode cap of the picture tube.
- 2) Turn on the receiver, set brightness and contrast controls to minimum. (Zero beam current)
- 3) Make sure the high voltage does not exceed 28kV.
 -) No matter whether the luminance, contrast and chrominance controls are set to maximum or minimum, the high voltage must be kept under 28kV.

HEIGHT ADJUSTMENT

- 1) Receive the Philips Pattern signal.
- 2) Adjust the height control (VR202) to slightly overscan the screen.

FOCUSING ADJUSTMENT

- 1) Receive the Philips Pattern signal.
- 2) Set the contrast control to the normal position.
- 3) Adjust focus control for a well-defined, sharpest display in the middle between center and side edge of the screen.

HORIZONTAL POSITION ADJUSTMENT

- 1) Receiver the Philips Pattern signal.
- 2) Adjust VR203 to change the horizontal position of the pattern for center.

ON-SCREEN POSITION ADJUSTMENT

- 1) Receive the Philips Pattern signal.
- 2) By pressing the PICTURE button.
- 3) Adjust on screen (VR001) for adjust the lettering to center of CRT.

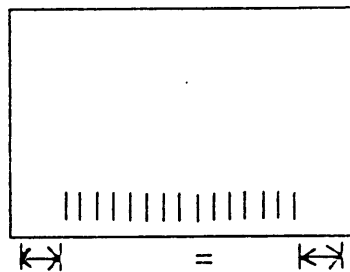

(FIG. 6)

GENERAL ADJUSTMENT

A. PAL COLOUR DEMODULATOR ADJUSTMENT

- 1) Receive Philips Pattern.
- 2) Set CONTRAST control to minimum position.
- 3) Set COLOUR control to maximum position.
- 4) Connect Oscilloscope to TP201 (B-out).
- 5) Adjust VR201 to obtain the waveform as shown in Fig 7.
- 6) Adjust L205 to obtain the waveform as shown in Fig 7.

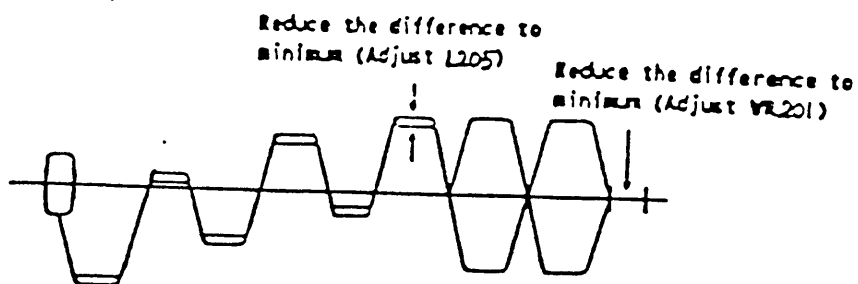

(FIG. 7)

B. WHITE BALANCE ADJUSTMENT

- 1) Receive the monoscope pattern.
- 2) Set the R.G.B. cut off controls (VR503, VR504, VR505) and the G.B. drive controls (VR501, VR502) at center position.
- 3) Rotate the screen control (on the FBT) fully counter clockwise. (minimum position)
- 4) Set the service switch (SW201) to 'Service' position.
- 5) Rotate the screen control gradually clockwise until the first horizontal line appears on the screen.
- 6) If the first horizontal line is in blue, adjust VR503, VR504 to increase the red and green component level to get a white horizontal line.
- 7) Reset the service switch (SW201) to 'Normal' position.
Set color to minimum.
Set brightness control to middle position.
Set contrast control to middle position.
- 8) Adjust drive controls (VR501, VR502) to maintain a good white balance at the brightest part of the screen.
- 9) Use white balance checker to fine adjust (VR503, VR504, VR505) at 25% brightness level and (VR501, VR502) at 75% brightness level.

C. SUB-BRIGHTNESS ADJUSTMENT

- 1) Receive the philips pattern signal.
- 2) Set the contract, brightness and colour controls to minimum position.
- 3) Adjust sub-brightness (VR204) until light just appears on the screen.

D. DELAY AGC ADJUSTMENT

- 1) Receive the signal of VHF High Channel.
- 2) Set input signal level at 60 +/-3dB.
- 3) ADjust AGC (VR101) control to point where noise is disappeared.
- 4) Increase input signal level to 100dB.
- 5) Check for normal picture, sound an sync.

COLOR PURITY AND CONVERGENCE ADJUSTMENT

A. COLOR PURITY ADJUSTMENT

NOTE : Before attempting any purity adjustments, the receiver should be operated for at least fifteen minutes.

- 1) Demagnetize the picture tube and cabinet using a degaussing coil.
- 2) Turn the contrast and brightness controls to maximum.
- 3) Adjust Red and Blue controls (VR503) and (VR505); to provide only a green raster. Advance the Green Bias Control (VR504) if necessary.
- 4) Loosen the clamp screw holding the yoke backward to provide vertical green belt (zone) in the picture screen.
- 5) Remove the Rubber Wedges.
- 6) Rotate and spread the tabs of the purity magnet as shown in Fig 13 around the neck of the picture tube until the green belt is in the center of the screen. At the same time, center the raster vertically.
- 7) Move the yoke slowly forward or backward until a uniform green screen is obtained. Tighten the clamp screw of the yoke temporarily.
- 8) Check the purity of the red and blue raster by adjusting the bias controls.
- 9) obtain a white raster, referring to white balance adjustment.
- 10) Proceed with convergence adjustment.

B. CONVERGENCE MAGNET ASSEMBLY POSITIONING

Convergence Magnet Assembly and Rubber Wedges need mechanical positioning as shown in Fig 11.

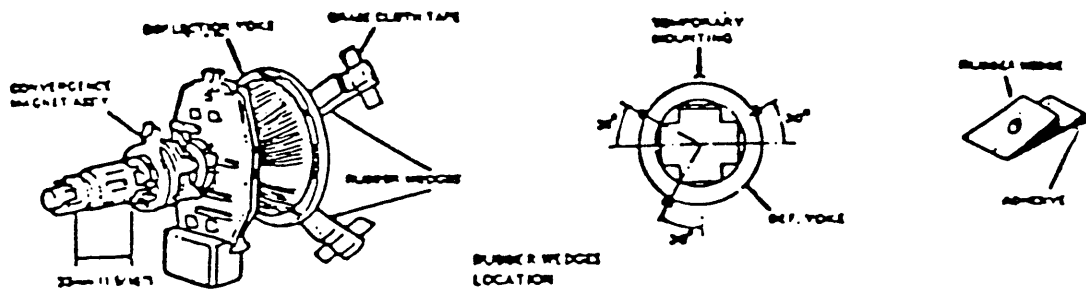

FIG. 11

CENTER CONVERGENCE ADJUSTMENT

NOTE : Before attempting any convergence adjustments, the receiver should be operated for at least fifteen minutes.

- 1) Receive crosshatch pattern with a color bar signal generator.
- 2) Adjust the brightness and contrast controls for well defined pattern.
- 3) Adjust two tabs of the 4 Pole Magnets to change the angle between them as shown in Fig 12 and superimpose red and blue vertical lines in the center area of the picture screen as shown in Fig 13.
- 4) Turn both tabs at the same time keeping the constant angle to superimpose red and blue horizontal lines at the center of screen as shown in Fig 13.
- 5) Adjust two tabs of 6 Pole Magnets to superimpose red/blue line with green one. Adjusting the angle affects the vertical lines and rotating both magnets affects the horizontal lines.
- 6) Repeat adjustment 3, 4, 5 keeping in mind red, green and blue movement, because 4 Pole Magnets and 6 Pole Magnets interact and make dot movement complex.

D. CIRCUMFERENCE CONVERGENCE ADJUSTMENT

NOTE : This adjustment requires Rubber Wedges and Glass Cloth Tapes.

- 1) Loosen the clamping screws of deflection yoke to allow the yoke to tilt.
- 2) Place a wedge . (Do not remove cover paper on adhesive part of the wedge).
- 3) Tilt front of the deflection yoke up or down to obtain better convergence in circumference as shown in Fig 13 Push the mounted wedge into the space between picture tube and the yoke to hold the yoke temporarily.
- 4) Place other wedge into bottom space and remove the cover part to stick.
- 5) Tilt front of the yoke right or left to obtain better convergence in circumference as shown in Fig 13.
- 6) Hold the yoke position and put another wedge in either upper space, remove cover paper and stick the wedge on picture tube to hold the yoke.
- 7) Detach the temporarily mounted wedge and put it in another upper space. Stick it on picture tube to fix the yoke.
- 8) After placing three wedges, recheck over all convergence. Tighten the screw firmly to hold the yoke tightly in place.
- 9) Stick 3 glass cloth tapes on wedges as shown in Fig 11.

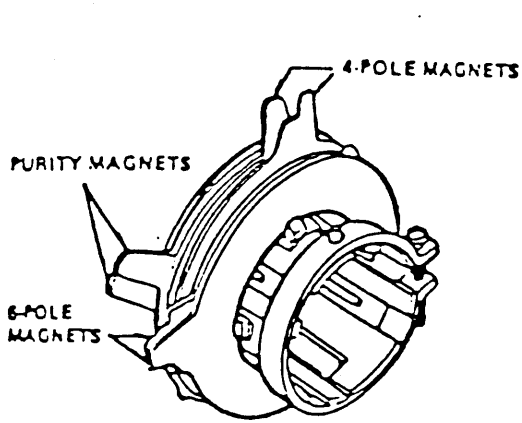

CONVERGENCE MAGNET ASSEMBLY

ADJUST THE ANGLE
(VERTICAL LINES)

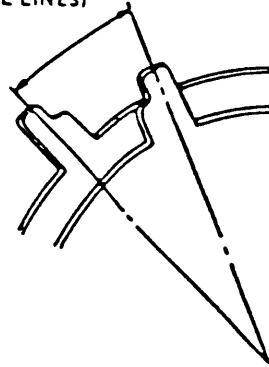

FIXED

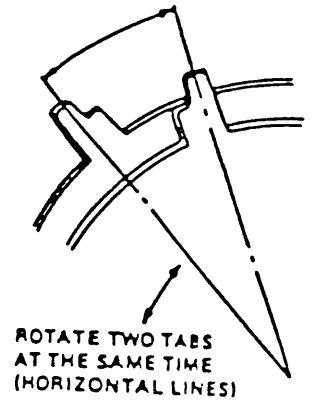
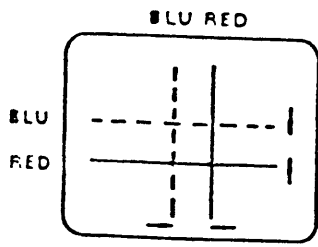
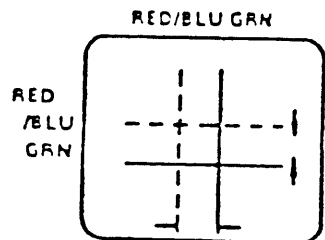

Fig. 12

ADJUSTMENT OF MAGNETS



4-Pole Magnet Movement



6-Pole Magnet Movement

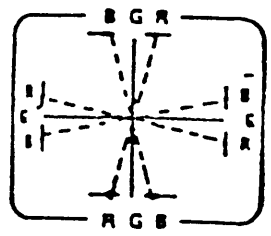

Incline the Yoke up (or down)

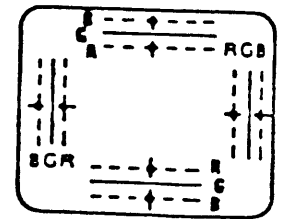

Incline the Yoke right (or left)

Center Convergence by Convergence Magnets

Circumference Convergence by DEF Yoke

Fig.13 Dot Movement Pattern

CT-480

SKYWORTH ELECTRONICS CO., LTD
BILL - OF - MATERIAL

MODEL NO : CTV-8208
BOM NO : 8148 E50+DN

DATE : JUN 8, 1995
JOB NO : 95032R

MAIN P. C. BOARD
ASSEMBLY NO. : 8148-A01002-00

PART NO.	DESCRIPTION	QTY	U/P	TOTAL
41AA-0100AD-31 RES.	1 OHM 1/4W +/-5%	3	0.0029	0.0087
41AA-1000AD-31 RES.	10 OHM 1/4W +/-5%	2	0.0029	0.0058
41AA-2200AD-31 RES.	22 OHM 1/4W +/-5%	1	0.0029	0.0029
41AA-6800AD-31 RES.	68 OHM 1/4W +/-5%	2	0.0029	0.0058
41AA-7500AD-31 RES.	75 OHM 1/4W +/-5%	5	0.0029	0.0145
41AA-1010AD-31 RES.	100 OHM 1/4W +/-5%	6	0.0029	0.0174
41AA-1510AD-31 RES.	150 OHM 1/4W +/-5%	3	0.0029	0.0087
41AA-2210AD-31 RES.	220 OHM 1/4W +/-5%	10	0.0029	0.0290
41AA-3310AD-31 RES.	330 OHM 1/4W +/-5%	2	0.0029	0.0058
41AA-3910AD-31 RES.	390 OHM 1/4W +/-5%	3	0.0029	0.0087
41AA-5110AD-31 RES.	510 OHM 1/4W +/-5%	1	0.0029	0.0029
41AA-5610AD-31 RES.	560 OHM 1/4W +/-5%	6	0.0029	0.0174
41AA-6810AD-31 RES.	680 OHM 1/4W +/-5%	2	0.0029	0.0058
41AA-8210AD-31 RES.	820 OHM 1/4W +/-5%	4	0.0029	0.0116
41AA-1020AD-31 RES.	1K OHM 1/4W +/-5%	11	0.0029	0.0319
41AA-1220AD-31 RES.	1K2 OHM 1/4W +/-5%	2	0.0029	0.0058
41AA-1520AD-31 RES.	1K5 OHM 1/4W +/-5%	4	0.0029	0.0116
41AA-1820AD-31 RES.	1K8 OHM 1/4W +/-5%	2	0.0029	0.0058
41AA-2220AD-31 RES.	2K2 OHM 1/4W +/-5%	6	0.0029	0.0174
41AA-2720AD-31 RES.	2K7 OHM 1/4W +/-5%	2	0.0029	0.0058
41AA-3020AD-31 RES.	3K OHM 1/4W +/-5%	1	0.0029	0.0029
41AA-3320AD-31 RES.	3K3 OHM 1/4W +/-5%	1	0.0029	0.0029
41AA-4720AD-31 RES.	4K7 OHM 1/4W +/-5%	2	0.0029	0.0058
41AA-5120AD-31 RES.	5K1 OHM 1/4W +/-5%	1	0.0029	0.0029
41AA-5620AD-31 RES.	5K6 OHM 1/4W +/-5%	6	0.0029	0.0174
41AA-6820AD-31 RES.	6K8 OHM 1/4W +/-5%	4	0.0029	0.0116
41AA-8220AD-31 RES.	8K2 OHM 1/4W +/-5%	4	0.0029	0.0116
41AA-1030AD-31 RES.	10K OHM 1/4W +/-5%	24	0.0029	0.0696
41AA-1230AD-31 RES.	12K OHM 1/4W +/-5%	5	0.0029	0.0145
41AA-1530AD-31 RES.	15K OHM 1/4W +/-5%	3	0.0029	0.0087
41AA-1830AD-31 RES.	18K OHM 1/4W +/-5%	2	0.0029	0.0058
41AA-2230AD-31 RES.	22K OHM 1/4W +/-5%	18	0.0029	0.0522
41AA-2730AD-31 RES.	27K OHM 1/4W +/-5%	7	0.0029	0.0203
41AA-3330AD-31 RES.	33K OHM 1/4W +/-5%	6	0.0029	0.0174
41AA-3930AD-31 RES.	39K OHM 1/4W +/-5%	2	0.0029	0.0058
41AA-4730AD-31 RES.	47K OHM 1/4W +/-5%	6	0.0029	0.0174
41AA-5630AD-31 RES.	56K OHM 1/4W +/-5%	1	0.0029	0.0029
41AA-1040AD-31 RES.	100K OHM 1/4W +/-5%	1	0.0029	0.0029
41AA-1540AD-31 RES.	150K OHM 1/4W +/-5%	2	0.0029	0.0058
41AA-2740AD-31 RES.	270K OHM 1/4W +/-5%	1	0.0029	0.0029
41AA-3940AD-31 RES.	390K OHM 1/4W +/-5%	1	0.0029	0.0029
41AA-1550AD-31 RES.	1M5 OHM 1/4W +/-5%	1	0.0029	0.0029
41AA-2200AF-31 RES.	22 OHM 1/2W +/-5%	1	0.0075	0.0075
41AA-5600AF-31 RES.	56 OHM 1/2W +/-5%	1	0.0075	0.0075
41AA-4710AF-31 RES.	470 OHM 1/2W +/-5%	1	0.0075	0.0075

SKYWORTH ELECTRONICS CO., LTD
BILL - OF - MATERIAL

MODEL NO : CTV-8208
BOM NO : 8148 E50+DN

DATE : JUN 8, 1995
JOB NO : 95032H

MAIN P. C. BOARD
ASSEMBLY NO. : 8148-A01002-00

PART NO.	DESCRIPTION	QTY	U/P	TOTAL
41AA-2720AP-31	RES. 2K7 OHM 1/2W +/-5%	1	0.0075	0.0075
41AA-1030AP-31	RES. 10K OHM 1/2W +/-5%	1	0.0075	0.0075
41AA-2230AP-31	RES. 22K OHM 1/2W +/-5%	1	0.0075	0.0075
41AA-1540AP-31	RES. 150K OHM 1/2W +/-5%	2	0.0075	0.0150
41AA-2220DF-32	RES. 2K2 OHM (MO) 1/2W +/-5%	2	0.0124	0.0248
41AA-1200DG-32	RES. 12 OHM (MO) 1W +/-5%	1	0.0169	0.0169
41AA-4720DG-32	RES. 4K7 OHM (MO) 1W +/-5%	1	0.0169	0.0169
41AA-1030DG-32	RES. 10K OHM (MO) 1W +/-5%	1	0.0169	0.0169
41AA-2230DG-32	RES. 22K OHM (MO) 1W +/-5%	1	0.0169	0.0169
41AA-3340DG-32	RES. 330K OHM (MO) 1W +/-5%	2	0.0169	0.0338
41AA-0220DH-32	RES. 2.2 OHM (MO) 2W +/-5%	2	0.0221	0.0442
41AA-2700DH-32	RES. 27 OHM (MO) 2W +/-5%	1	0.0221	0.0221
41AA-1230DI-32	RES. 12K OHM (MO) 3W +/-5%	1	0.0429	0.0429
41AA-8220DI-32	RES. 8K2 OHM (MO) 3W +/-5%	1	0.0429	0.0429
41AA-5120DR-32	RES. 5K1 OHM (MO) 5W +/-5%	1	0.0780	0.0780
41AA-0068EG-32	RES. 0.68 OHM (F) 1W +/-5%	3	0.0351	0.1053
41PH-8250HG-31	RES. 8M2 OHM (MO) 1W +/-5%	1	0.1430	0.1430
41AA-0033PH-31	RES. 0.33 OHM (NI) 2W +/-5%	1	0.0550	0.0550
41RA-0220FH-31	RES. 2.2 OHM (NI) 2W +/-5%	1	0.0584	0.0584
41AA-0400FK-32	CEMENT FIXED RES. 4 OHM 5W +/-5%	1	0.0699	0.0699
41AA-3900FL-31	CEMENT FIXED RES. 39 OHM 6W +/-5%	1	0.0750	0.0750
41AA-1800KZ-FA	PTC THERMISTER 250V 180M290	1	0.3167	0.3167
42AA-1020BB-51	SEMI-FIXED RES. 1 KB (H)	2	0.0467	0.0934
42AA-5020BB-51	SEMI-FIXED RES. 5 KB (H)	1	0.0467	0.0467
42AA-1030BB-51	SEMI-FIXED RES. 10 KB (H)	1	0.0467	0.0467
42AA-5030BB-51	SEMI-FIXED RES. 50 KB (H)	2	0.0467	0.0934
42AA-2010BB-51	SEMI-FIXED RES. 200 OHM (H)	1	0.0467	0.0467
43AA-A150FC-00	C. CAP. 15 PF 50V +/-5%	1	0.0083	0.0083
43AA-A180FC-00	C. CAP. 18 PF 50V +/-5%	1	0.0083	0.0083
43AA-A270FC-00	C. CAP. 27 PF 50V +/-5%	1	0.0083	0.0083
43AA-A330FC-00	C. CAP. 33 PF 50V +/-5%	1	0.0083	0.0083
43AA-A390FC-00	C. CAP. 39 PF 50V +/-5%	1	0.0083	0.0083
43AA-A680FC-00	C. CAP. 68PF 50V +/-5%	1	0.0083	0.0083
43AA-A101FC-00	C. CAP. 100 PF 50V +/-5%	3	0.0083	0.0249
43AA-A181FC-00	C. CAP. 180 PF 50V +/-5%	4	0.0100	0.0400
43AA-A241FC-00	C. CAP. 240 PF 50V +/-5%	1	0.0108	0.0108
43AA-A331FC-00	C. CAP. 330 PF 50V +/-5%	1	0.0125	0.0125
43AA-A103FH-00	C. CAP. 0.01 UF 50V +80 -20%	19	0.0083	0.1577
43AA-A223FH-00	C. CAP. 0.022 UF 50V +80 -20%	2	0.0083	0.0166
43AA-A104FH-00	C. CAP. 0.1 UF 50V +80 -20%	4	0.0267	0.1068
43AA-A224DH-00	C. CAP. 0.22 UF 25V +80 -20%	1	0.0333	0.0333
43AA-A681MD-00	C. CAP. 680 PF 500V +/-10%	5	0.0367	0.1835
43AA-A472MD-00	C. CAP. 0.0047 UF 500V +/-10%	4	0.0467	0.1868
43AA-A222MD-00	C. CAP. 0.0022 UF 500V +/-10%	1	0.0467	0.0467
43AA-A222RD-00	C. CAP. 0.0022 UF 1KV +/-10%	1	0.0800	0.0800

SKYWORTH ELECTRONICS CO., LTD
BILL - OF - MATERIAL

MODEL NO : CTV-8208
BOM NO : 8148 E50+DN

DATE : JUN 8, 1995
JOB NO : 95032H

MAIN P. C. BOARD
ASSEMBLY NO. : 8148-A01002-00

PART NO.	DESCRIPTION	QTY	U/P	TOTAL
43AA-A473MD-00	C. CAP. 0.047 UF 500V +80 -20%	1	0.1000	0.1000
43AA-A202FH-00	C. CAP. 0.002 UF 50V +80 -20%	2	0.0083	0.0166
43AA-W220FC-00	NPO 22 PF 50V +/-5%	1	0.0092	0.0092
* 43AA-N300FC-00	NPO 30 PF 50V +/-5%	2	0.0092	0.0184
43AA-B106CE-00	E. CAP. 10 UF 16V +/-20%	6	0.0195	0.1170
43AA-B226CE-00	E. CAP. 22 UF 16V +/-20%	7	0.0195	0.1365
43AA-B107CE-00	E. CAP. 100 UF 16V +/-20%	7	0.0433	0.3031
43AA-B227CE-00	E. CAP. 220 UF 16V +/-20%	3	0.0437	0.1311
43AA-B477CE-00	E. CAP. 470 UF 16V +/-20%	1	0.0650	0.0650
43AA-B476DE-00	E. CAP. 47 UF 25V +/-20%	2	0.0250	0.0500
43AA-B477DE-00	E. CAP. 470 UF 25V +/-20%	3	0.0917	0.2751
43AA-B108DE-00	E. CAP. 1000 UF 25V +/-20%	1	0.1533	0.1533
43AA-B228DE-00	E. CAP. 2200 UF 25V +/-20%	1	0.2734	0.2734
43AA-B107EE-00	E. CAP. 100 UF 35V +/-20%	2	0.0484	0.0968
43AA-B104FE-00	E. CAP. 0.1 UF 50V +/-20%	2	0.0195	0.0390
43AA-B224FE-00	E. CAP. 0.22 UF 50V +/-20%	1	0.0195	0.0195
43AA-B474FE-00	E. CAP. 0.47 UF 50V +/-20%	7	0.0195	0.1365
43AA-B105FE-00	E. CAP. 1 UF 50V +/-20%	7	0.0195	0.1365
43AA-B225FE-00	E. CAP. 2.2 UF 50V +/-20%	4	0.0195	0.0780
43AA-B475FE-00	E. CAP. 4.7 UF 50V +/-20%	5	0.0195	0.0975
43AA-B106FE-00	E. CAP. 10 UF 50V +/-20%	2	0.0225	0.0450
43AA-B226FE-00	E. CAP. 22 UF 50V +/-20%	2	0.0242	0.0484
43AA-B476FE-00	E. CAP. 47 UF 50V +/-20%	1	0.0342	0.0342
OR 43AA-B476FE-01	E. CAP. 105C 47 UF 50V +/-20%	1	0.0967	0.0967
43AA-B476FE-00	E. CAP. 47 UF 50V +/-20%		0.0342	0.0000
43AA-B105HE-00	E. CAP. 1 UF 160V +/-20%	1	0.0484	0.0484
43AA-B107HE-00	E. CAP. 100 UF 160V +/-20%	2	0.2883	0.5766
43AA-B106JE-00	E. CAP. 10 UF 250V +/-20%	1	0.1300	0.1300
43AA-B107LE-00	E. CAP. 100 UF 400V +/-20%	1	0.9083	0.9083
43AA-E563JC-00	METALLIZED POLY. 0.056 UF 250V +/-5%	1	0.0611	0.0611
43AA-E332SC-00	METALLIZED POLY. 0.0033 UF 1K6V +/-5%	1	0.2210	0.2210
43AA-M224FC-00	METALLIZED POLY. 0.22 UF 63V +/-5%	7	0.5850	4.0950
OR 43PH-E224GD-00	METALLIZED PE CAP. 0.22 UF 100V +/-10%		0.0468	0.0000
43AA-M474FC-00	METALLIZED POLY. 0.47 UF 63V +/-5%	1	0.0910	0.0910
OR 43PH-E474GD-00	METALLIZED PE CAP. 0.47 UF 100V +/-10%		0.0738	0.0000
43AA-E224WD-30	METALLIZED POLY. 0.22 UF AC250V +/-10%	1	0.2200	0.2200
43AA-E474WD-30	METALLIZED POLY. 0.47 UF AC250V +/-10%	1	0.3575	0.3575
43MO-P222XE-30	AC CAP. 0.0022UF AC400V DR141 +/-20%	1	0.2380	0.2380
43AA-L225FE-00	N. P. CAP. 2.2 UF 50V +/-20%	1	0.0433	0.0433
43AA-G105ED-00	TANTALUM 1 UF 35V +/-10%	1	0.0716	0.0716
43AA-G225ED-00	TANTALUM 2.2 UF 35V +/-10%	1	0.0900	0.0900
43AA-M102GD-00	MYLAR CAP. 0.001 UF 100V +/-10%	2	0.0108	0.0216
43AA-M222GD-00	MYLAR CAP. 0.0022 UF 100V +/-10%	1	0.0108	0.0108
43AA-M682GD-00	MYLAR CAP. 0.0068 UF 100V +/-10%	1	0.0108	0.0108
43AA-M103GD-00	MYLAR CAP. 0.01 UF 100V +/-10%	3	0.0134	0.0402

SKYWORTH ELECTRONICS CO., LTD
BILL - OF - MATERIAL

MODEL NO : CTV-8208
BOM NO : 8148 E50+DN

DATE : JUN 8, 1995
JOB NO : 95032H

MAIN P. C. BOARD
ASSEMBLY NO. : 8148-A01002-00

PART NO.	DESCRIPTION	QTY	U/P	TOTAL
43AA-M183GD-00	MYLAR CAP. 0.018 UF 100V +/-10%	1	0.0142	0.0142
43AA-M223GD-00	MYLAR CAP. 0.022 UF 100V +/-10%	2	0.0142	0.0284
43AA-M333GD-00	MYLAR CAP. 0.033 UF 100V +/-10%	3	0.0153	0.0459
43AA-M473GD-00	MYLAR CAP. 0.047UF 100V +/-10%	1	0.0183	0.0183
43AA-M104GD-00	MYLAR CAP. 0.1 UF 100V +/-10%	5	0.0250	0.1250
OR 43AA-M104GD-00	METALLIZED PE CAP. 0.22 UF 100V +/-10%	1	0.0467	0.0467
45AA-403V91-51	DIODE 3V9 0.5W	1	0.0225	0.0225
45AA-405V61-51	DIODE 5V6 0.5W	1	0.0225	0.0225
45AA-407V51-51	DIODE 7V5 0.5W	2	0.0225	0.0450
45AA-408V21-51	DIODE 8V2 0.5W	1	0.0225	0.0225
45AA-409V11-51	DIODE 9V1 0.5W	3	0.0225	0.0675
45AA-4020V1-51	DIODE 20V 0.5W	1	0.0225	0.0225
45TF-2BYT52-01	DIODE BYT52J	12	0.0800	0.9600
45SA-6BA10G-01	DIODE DBA10G	1	0.3718	0.3718
OR 45TO-6J4B41-00	BRIDGERECTIFIER (1A1J4B41		0.3250	0.0000
47SS-KA33VA-02	I.C. KA33V	1	0.1166	0.1166
OR 47UN-UZT330-02	I.C. UZT33T		0.1166	0.0000
46TO-A1015Y-00	TRANSISTOR 2SA1015Y	1	0.0247	0.0247
46TO-C1815Y-00	TRANSISTOR 2SC1815Y	16	0.0241	0.3856
46TO-C27170-00	TRANSISTOR 2SC2717	1	0.1131	0.1131
46TO-C24822-01	TRANSISTOR 2SC2482	1	0.0832	0.0832
4605-H315D0-00	TRANSISTOR BUH315D	1	0.7280	0.7280
4605-H31500-00	TRANSISTOR BUH315	1	0.7280	0.7280
46TO-A10130-01	TRANSISTOR 2SA1013	1	0.1066	0.1066
46TO-C2230A-01	TRANSISTOR 2SC2230	1	0.0676	0.0676
46NE-C2335K-42	TRANSISTOR 2SC2335	1	0.3766	0.3766
46SA-D4000E-00	TRANSISTOR 2SD400	1	0.0750	0.0750
OR 46TO-C27030-00	TRANSISTOR 2SC2703		0.0754	0.0000
46MA-B7740Q-00	TRANSISTOR 2SB774	1	0.1088	0.1088
46SG-SSX203-00	TRANSISTOR BSX20	1	0.1755	0.1755
* 47MI-M34004-42	I.C. M34300W4 (CPU)	1	4.2250	4.2250
47TO-A8659H-64	I.C. TA8659AN (VIDEO)	1	5.2000	5.2000
47SA-L7830V-07	I.C. LA7830 (VERTICAL)	1	0.9000	0.9000
OR 47TO-484030-07	I.C. TA8403K		0.5460	0.0000
47SA-L7910B-09	I.C. LA7910 (BAND SW.)	1	0.2405	0.2405
OR 47DW-W20440-09	I.C. DBL2044		0.2405	0.0000
47SG-L7805E-03	I.C. L7805CV (STABILIZING)	1	0.2340	0.2340
47SG-L7812E-03	I.C. L7812CV (STABILIZING)	1	0.2340	0.2340
47SG-A1904A-16	I.C. TDA1904 (SOUND)	1	0.4550	0.4550
47SG-D82220-24	I.C. TDA8222 (IF)	1	1.5600	1.5600
48AA-061004-00	AC LINE FILTER 1 mH x 2	1	0.3167	0.3167
48AA-063005-00	AC LINE FILTER 35mH x 2	1	0.7167	0.7167
48AA-190404-00	TRAP COIL 40.4 MHz	1	0.1334	0.1334
48AA-200389-00	PIF DET COIL	1	0.1334	0.1334
48AA-210380-10	AFC COIL	1	0.1334	0.1334

SKYWORTH ELECTRONICS CO., LTD
BILL - OF - MATERIAL

MODEL NO : CTV-8208
BOM NO : 8148 E50+DN

DATE : JUN 8, 1995
JOB NO : 95032H

MAIN P. C. BOARD
ASSEMBLY NO. : 8148-A01002-00

PART NO.	DESCRIPTION	QTY	U/P	TOTAL
48AA-190055-00	SIP DET	1	0.1100	0.1100
48AA-220072-00	MATCHING COIL	1	0.1334	0.1334
48AA-021003-00	CHOKO COIL	2	0.0699	0.1398
48AA-010082-00	PEAKING COIL	1	0.0283	0.0283
48AA-010820-00	PEAKING COIL	2	0.0283	0.0566
48AA-011000-00	PEAKING COIL	1	0.0283	0.0283
48AA-012700-00	PEAKING COIL	1	0.0283	0.0283
4902-243042-00	CERAMIC RESONATOR	1	0.2167	0.2167
49AA-5003F2-20	CERAMIC RESONATOR	1	0.1667	0.1667
49AA-550406-30	CERAMIC FILTER	1	0.1500	0.1500
49AA-550405-30	CERAMIC TRAP	1	0.1867	0.1867
49AA-443401-20	CRYSTAL	1	0.3167	0.3167
49SI-187203-50	IF 38.9MHZ SAW FILTER (BG)	1	0.1080	0.1080
OR 49TO-104403-51	IF 38.9MHZ SAW FILTER (BG)	1	0.8840	0.8840
51AA-04110N-00	HORIZONTAL DRIVE	1	0.2084	0.2084
51AA-06110V-00	SWITCHING TRANSFORMER	1	1.4166	1.4166
55IT-020200-02	POWER SWITCH	1	0.0459	0.0459
52AL-389552-00	TV TUNER BG TEKEI-033A ALPS	1	8.4500	8.4500
* 53SR-145818-00	REMOTE CONTROL RECEIVER	1	0.8834	0.8834
OR 53TF-145380-00	REMOTE CONTROL RECEIVER	1	0.8667	0.8667
5405-220302-02	2 PIN HOUSING + 300MM WIRE X 2 #24 1007 B/W	1	0.1134	0.1134
* 54AA-235222-CB	3 PIN HOUSING + 350mm WIRE AWG22	1	0.2016	0.2016
54AA-950000-EA	WAFER	1	0.0767	0.0767
54AA-925000-BA	WAFER	2	0.0166	0.0332
54AA-910100-BA	WAFER	1	0.0283	0.0283
54AA-950000-CB	WAFER	1	0.0501	0.0501
55AA-020250-00	SWITCH	1	0.0333	0.0333
* 55AA-010222-00	TACT SWITCH (VERTICAL TYPE)	10	0.0584	0.5840
* 56AA-108051-23	SPEAKER	1	1.0167	1.0167
57AA-A50120-00	GAP LED LIGHT EMISSION (LONG LEAD) 0 3.1mm AL-3RD4	1	0.0317	0.0317
* 58AA-B8148A-03	P.C. BOARD (94V-0) MAIN	1	2.4383	2.4383
59AA-G40106-00	COPPER JUMPER	113	0.0008	0.0904
59AA-N14224-05	PLAT CABLE 5 PIN 140mm AWG24 UL BLACK 2.5mm PITCH	1	0.0355	0.0355
* 5905-A27375-02	SAA 9' V/HOLDER (FOR AUSTRALIA)	1	0.5916	0.5916
59AA-B60122-OA	WIRE AWG22 1015 60mm	1	0.0055	0.0055
60AA-350001-00	T3.15A 250V	1	0.0867	0.0867
61AA-160320-00	RCA JACK AUDIO I/O BLACK	1	0.1466	0.1466
61AA-160320-40	RCA JACK VIDEO I/O YELLOW	1	0.1466	0.1466
65AA-114147-20	DELAY LINE	1	0.3333	0.3333
65AA-235234-20	DELAY LINE	1	0.6917	0.6917
H 41AA-0100AD-31	RES.	1	0.0029	0.0029
H 41AA-2210AD-31	RES.	1	0.0029	0.0029
H 43AA-A101PC-00	C. CAP	2	0.0083	0.0166
H 43AA-B476AE-02	E. CAP	1	0.0442	0.0442
H 45AA-141481-00	DIODE	7	0.0083	0.0581

SKYWORTH ELECTRONICS CO., LTD
BILL - OF - MATERIAL

MODEL NO : CTV-8208
BOM NO : 8148 E50+DN

DATE : JUN 8, 1995
JOB NO : 95032H

MAIN P. C. BOARD
ASSEMBLY NO. : 8148-A01002-00

PART NO.	DESCRIPTION	QTY	U/P	TOTAL
H 45T0-8N1050-00	INFRARED DIODE TLN105B	2	0.1235	0.2470
H 46T0-C2120Y-00	TRANSISTOR 2SC2120Y	1	0.0390	0.0390
H 47M1-M50560-20	I.C. M50560-001P	1	0.8580	0.8580
H 49AA-455302-21	CERAMIC RESONATOR 455KHz	1	0.1833	0.1833
H 58AA-B8213F-02	HANDSET P.C. BOARD	1	0.4467	0.4467
5005-48010A-52	20" ORION SOUTH CRT A48JLL92X27	1	91.0000	91.0000
5800-C82182-00	CRT PC BOARD	1	0.2466	0.2466
5101-051100-00	FLYBACK TRANSFORMER JF0501-0500B	1	7.4100	7.4100
41AA-0150DH-32	METAL OXIDE FILM 1.5OHM 2W	1	0.0221	0.0221
43AA-B682TC-00	METALLIZED POLY CAP 0.0068UF 2KV	1	0.2860	0.2860
43AA-B472TC-00	METALLIZED POLY CAP 0.0047UF 2KV	1	0.2275	0.2275
48AA-044402-00	LINEAR COIL 44UH	1	0.2666	0.2666
48AA-081400-00	DEGAUSSING COIL	1	0.8834	0.8834
58AA-B8208R-00	RECEIVER PCB	1	0.0833	0.0833
59AA-C60124-00	60MM WIRE AWG24 1007 BLACK	1	0.0035	0.0035
59AA-C60124-00	60MM WIRE AWG24 1007 RED	1	0.0035	0.0035
59AA-C60124-30	60MM WIRE AWG24 1007 ORANGE	1	0.0035	0.0035
59AA-C60124-40	60MM WIRE AWG24 1007 YELLOW	1	0.0035	0.0035
54AA-150224-EA	5 PIN +500MM WIRE AWG24 1007	1	0.0584	0.0584
54AA-238222-AB	1 PIN HOUSING + 380MM AWG22 1015 CRT GROUND	1	0.0584	0.0584
43AA-B474JC-00	C CAP 0.47UF 250V +/-5%	1	0.1690	0.1690
43AA-A150PC-00	C CAP 15PF 50V +/-5%	1	0.0083	0.0083
43AA-A220PC-00	C CAP 22PF 50V +/-5%	1	0.0083	0.0083
43AA-A150PC-00	C CAP 15PF 50V +/-5%	1	0.0083	0.0083
41AA-1830AD-31	RES 18K 1/4W +/-5%	1	0.0029	0.0029

SEE C.R.T TABLE

CRT P.C. BOARD
ASSEMBLY NO. : 8218-C01001-01

PART NO.	DESCRIPTION	QTY	U/P	TOTAL
41AA-1010AD-31	RES. 100 OHM 1/4W +/-5%	2	0.0029	0.0058
41AA-1510AD-31	RES. 150 OHM 1/4W +/-5%	1	0.0029	0.0029
41AA-3310AD-31	RES. 330 OHM 1/4W +/-5%	1	0.0029	0.0029
41AA-4710AD-31	RES. 470 OHM 1/4W +/-5%	3	0.0029	0.0087
41AA-8210AD-31	RES. 820 OHM 1/4W +/-5%	1	0.0029	0.0029
41AA-1020AD-31	RES. 1K OHM 1/4W +/-5%	1	0.0029	0.0029
41AA-2220AD-31	RES. 2K2 OHM 1/4W +/-5%	3	0.0029	0.0087
41AA-3020AD-31	RES. 3K OHM 1/4W +/-5%	3	0.0029	0.0087
41AA-5120AD-31	RES. 5K1 OHM 1/4W +/-5%	1	0.0029	0.0029
41AA-9120AD-31	RES. 9K1 OHM 1/4W +/-5%	3	0.0029	0.0087
41AA-1040AD-31	RES. 100K OHM 1/4W +/-5%	1	0.0029	0.0029
41AA-2720DF-32	RES. 2K7 OHM (NO) 1/2W +/-5%	3	0.0124	0.0372
41AA-1240DF-32	RES. 120K OHM (NO) 1/2W +/-5%	3	0.0124	0.0372

SKYWORTH ELECTRONICS CO., LTD
BILL - OF - MATERIAL

MODEL NO : CTV-8208
BOM NO : 8148 E50+DM

DATE : JUN 8, 1995
JOB NO : 95032H

MAIN P. C. BOARD
ASSEMBLY NO. : 8148-A01002-00

PART NO.	DESCRIPTION	QTY	U/P	TOTAL
41AA-1530DH-32	RES. 15K OHM (NO) 2W +/-5%	3	0.0221	0.0663
42KA-2020BB-50	SEMI-FIXED RES. 2KB(V)	5	0.0484	0.2420
43AA-A560FC-00	C. CAP 56 PF 50V +/-5%	3	0.0008	0.0024
43AA-A103FH-00	C. CAP 0.01 UF 50V +80-20%	1	0.0083	0.0083
43AA-A104FH-00	C. CAP 0.1 UF 50V +80-20%	1	0.0267	0.0267
43TE-A472TD-00	C. CAP 0.0047 UF 2KV +/-10%	1	0.1000	0.1000
43AA-B106CE-00	E. CAP 10 UF 16V +/-20%	1	0.0195	0.0195
43AA-B107CE-00	E. CAP 100 UF 16V +/-20%	1	0.0433	0.0433
43AA-B474FE-00	E. CAP 0.47 UF 50V +/-20%	1	0.0195	0.0195
45AA-141481-00	DIODE 0.5 W 1N4148	3	0.0083	0.0249
46TO-C1815Y-00	TRANSISTOR 2SC1815Y	1	0.0241	0.0241
46TO-C24822-01	TRANSISTOR 2SC2482	6	0.0832	0.4992
46TO-A5620T-00	TRANSISTOR 2SA562	1	0.0338	0.0338
54AA-300000-AA	TERMINAL 1 PIN 005P-1100	1	0.0117	0.0117
58AA-B8218C-04	C.R.T P.C.BOARD	1	0.3567	0.3567
61AA-06216B-22	C.R.T SOCKET 22mm	1	0.5500	0.5500
1 0122-008208-14	CARTON BOX "TEAC" CT-M480	1	3.0833	3.0833
0200-000100-00	PEARL SPONGE SHEET 16" X 29"	1	0.0833	0.0833
0202-000100-00	SPONGE CUSHION - FOR BATT CONTACT	1	0.0081	0.0081
2 0301-820800-00	POLYFOAM END CAP. - R & L (TOP & BOTTOM) <8208>	1	1.1967	1.1967
3 0404-030090-03	POLYBAG - FOR HANDSET 3" X 9" X 0.04MM (PO) W/PE	1	0.0455	0.0455
4 0404-090140-03	POLYBAG - FOR ACCESSORIES 14" X 9" X 0.04 MM (PO) W/PE	1	0.0126	0.0126
5 0404-380400-03	POLYBAG FOR UNIT - 26+12" X 40" X 0.04MM (PO) W/PE	1	0.1483	0.1483
0501-020148-02	WARRANTY CARD	1	0.0800	0.0800
0600-050008-64	BAR CODE LABEL (9313060006112)	1	0.0250	0.0250
6 0602-010008-64	BACK LABEL "TEAC" CT-M480	1	0.0833	0.0833
0602-030008-64	SCREEN LABEL	1	0.5500	0.5500
0602-040008-64	SHIPPING MARK LABEL (1ST SHIPMENT)	1	0.0800	0.0800
0602-040108-64	SHIPPING MARK LABEL (2ND SHIPMENT)	1	0.0800	0.0800
7 0602-200218-00	QC PASSED LABEL - WHITE	3	0.0013	0.0039
8 0602-201218-00	QC PASSED LABEL - GOLD	1	0.0013	0.0013
0602-250048-64	TEAC TOTAL CARE LABEL	1	0.0250	0.0250
9 0604-020219-00	SERIAL NO. LABEL (FOR OVERSEAS)	2	0.0066	0.0132
10 0702-368208-10	INSTRUCTION BOOKLET - "TEAC" CT-M480	1	0.1251	0.1251
11 0801-0M3AA0-04	BATTERY (UM-3AA) (R6M)	2	0.0367	0.0734
12 0902-000010-01	NAME PLATE - PVC "TEAC"	1	0.2666	0.2666
1001-202208-02	FRONT CAB - MAT GREY #H2476	1	5.1750	5.1750
13 1002-102208-00	BACK CABINET - BLACK (HIPS) <8208>	1	5.6333	5.6333
14 1005-122148-00	JACK PLATE BRACKET - BLACK (HIPS) <8148>	1	0.1009	0.1009
1006-212208-06	CONTROL DOOR - MAT GREY W/S GREY	1	0.1750	0.1750
15 1007-313208-11	FRONT LENS - DARK RED W/S GREY	1	0.1024	0.1024
16 1009-101208-00	POWER KNOB - BLACK (ABS)	1	0.0150	0.0150
17 1010-112208-00	CABINET MTG. HOLDER - BLK. (HIPS) <8208>	2	0.0433	0.0866
18 1011-201213-00	POWER ROD - (ABS) <8213>	1	0.0200	0.0200

SKYWORTH ELECTRONICS CO., LTD
BILL - OF - MATERIAL

MODEL NO : CTV-8208
BOM NO : 8148 E50+DN

DATE : JUN 8, 1995
JOB NO : 95032H

MAIN P. C. BOARD
ASSEMBLY NO. : 8148-A01002-00

PART NO.	DESCRIPTION	QTY	U/P	TOTAL
19 1012-102218-00	LED HOLDER	1	0.0166	0.0166
20 1014-111218-00	TOP CABINET - BLACK (ABS) HANDSET	1	0.2500	0.2500
21 1015-111218-00	BOTTOM CABINET - BLACK (ABS) HANDSET	1	0.1500	0.1500
22 1016-111218-00	BATTERY DOOR - BLACK (ABS) HANDSET	1	0.0083	0.0083
23 1017-313218-00	INFRARED LENS - DARK RED (SAN) HANDSET	1	0.0083	0.0083
24 1018-500218-00	INSULATOR RING - DIA. 4.1	1	0.0200	0.0200
25 1019-400218-00	WIRE HOLDER	2	0.0667	0.1334
26 1020-102148-00	P.C.B SUPPORTER	1	0.0200	0.0200
27 1021-102208-00	INFRARED PCB HOLDER (HIPS) <8208> BLACK	1	0.0300	0.0300
28 1022-102208-00	INSERT - BLACK (HIPS)	1	0.0750	0.0750
29 1129-814800-00	RUBBER KEYPAD 29 KEYS HANDSET	1	0.2466	0.2466
30 1210-038208-13	CONTROL FUNCTION - INLAY 10 KEYS	1	0.0467	0.0467
31 1210-058148-14	JACK PLATE - INLAY/RCA JACK	1	0.0550	0.0550
32 1226-S00001-06	HANDSET INLAY - 26 KEYS "TEAC"	1	0.0833	0.0833
1305-280025-00	TAPE - 1" X 11"	3	0.0450	0.1350
33 1404-108208-13	SPEAKER GRILLE 0.45 MILD STEEL MAT GREY "LEFT" <8208>	1	0.1833	0.1833
34 1404-108208-23	SPEAKER GRILLE 0.45 MILD STEEL MAT GREY "RIGHT" <8208>	1	0.1833	0.1833
35 1502-028218-00	CRT MTG. BRACKET - 2.0 MILD STEEL W/ZINC PLATE	4	0.0601	0.2404
36 1503-038218-00	FUSE HOLDER	2	0.0125	0.0250
37 1505-018218-08	HEAT SINK (9) - FOR IC 7805	1	0.0367	0.0367
38 1505-018218-12	HEAT SINK (2) - FOR Q604	1	0.1784	0.1784
39 1505-018218-30	HEAT SINK (1) - FOR IC302, Q301	1	0.3116	0.3116
40 1509-028148-00	SEAL CAN FRAME	1	0.1000	0.1000
41 1510-068208-00	FIBER PLATE	1	0.0300	0.0300
42 1800-300000-01	KNITTING COPPER WIRE - 760MM FOR GROUNDING	760mm	10.8333	0.0000
43 1901-008218-10	POWER KNOB SPRING - DIA. 0.6 SPRING WIRE	1	0.0100	0.0100
44 1902-008218-10	GROUNDING WIRE SPRING - FOR KNITTED WIRE	2	0.0300	0.0600
45 1903-008218-10	GROUNDING WIRE - DIA 0.6	2	0.0134	0.0268
46 2202-MS0004-00	DOOR LOCK - MS00	1	0.0967	0.0967
47 2401-000400-00	CABLE TIE - L=4"	5	0.0029	0.0145
48 2401-001100-00	CABLE TIE - L=11"	2	0.0179	0.0358
49 2402-000400-00	COLOUR TIE - L=100MM	3	0.0013	0.0039
50 2502-011205-01	SOLDER LUG 0.5MM BRASS	2	0.0100	0.0200
51 26BA-035120-B0	BA 3.5 X 12 - FOR JACK PLATE BKT.	2	0.0026	0.0052
52 26BA-035200-B0	BA 3.5 X 20 - FOR FRONT & BACK CABINET (BLACK)	4	0.0035	0.0140
53 26BA-035200-W0	BA 3.5 X 20 - CRT MTG. BRACKET	12	0.0035	0.0420
54 26BA-040120-B0	BA 4 X 12 - FOR PLYBACK (BLACK)	1	0.0040	0.0040
55 26BM-030100-W0	BM 3 X 10 - FOR Q601, IC301, IC202	3	0.0016	0.0048
56 26BM-030120-W0	BM3X12 - FOR Q302	1	0.0017	0.0017
57 26KH-030120-B0	KH 3 X 12 - FOR JACK PLATE BKT./21 PINS SOCKET MTG.	2	0.0018	0.0036
58 26PA-030080-W0	PA 3 X 8 - FOR HEAT 1 & 2 MTG./1 PCB SUPPORTER	5	0.0012	0.0060
59 26WA-030080-W0	WA 3 X 8 - 4 SPEAKER/2 FIBER PLATE MTG.	6	0.0014	0.0084
60 27MH-M3050N-03	M3 NUT - 1 HEAT SINK /1 TRANSISTOR/2 IC MTG.	4	0.0004	0.0016
61 27MH-M60A0N-05	M6 NUT - PICTURE TUBE	4	0.0250	0.1000
62 2801-030810-F0	FIBRE WASHER - 3 X 8 X 1 FOR SPEAKER MTG.	2	0.0083	0.0166

SKYWORTH ELECTRONICS CO., LTD
BILL - OF - MATERIAL

MODEL NO : CTV-8208
BOM NO : 8148 E50+DN

DATE : JUN 8, 1995
JOB NO : 95032H

MAIN P. C. BOARD
ASSEMBLY NO. : 8148-A01002-00

PART NO.	DESCRIPTION	QTY	U/P	TOTAL
63 2801-062230-R0	RUBBER WASHER - DIA 6 X 22 X 3	4	0.0159	0.0636
64 2802-030508-M2	M3 SPRING WASHER - FOR Q601 , Q302, IC301, IC202	4	0.0010	0.0040
65 2901-036060-00	EYELET - DIA. 3.6 X 6 CRT GROUNDING WIRE	2	0.0034	0.0068
66 3560-010004-01	BATTERY CONTACT "+"	1	0.0200	0.0200
67 3560-010005-01	BATTERY CONTACT "-"	1	0.0217	0.0217
68 3560-010006-01	BATTERY CONTACT "+" & "-"	1	0.0166	0.0166
69 3801-050000-00	HEAT-SHRINKABLE TUBE DIA 5.0MM L=20MM FOR AC LINE CORD	40m	0.4333	0.0000
70 3802-015000-00	FIBRE GLASS SLEEVING DIA. 1.5MM (20MMX6,12MMX4)	376mm	0.0750	0.0000
3803-060000-00	PVC TUBE - DIA L= 240MM	240mm	0.0003	0.0000

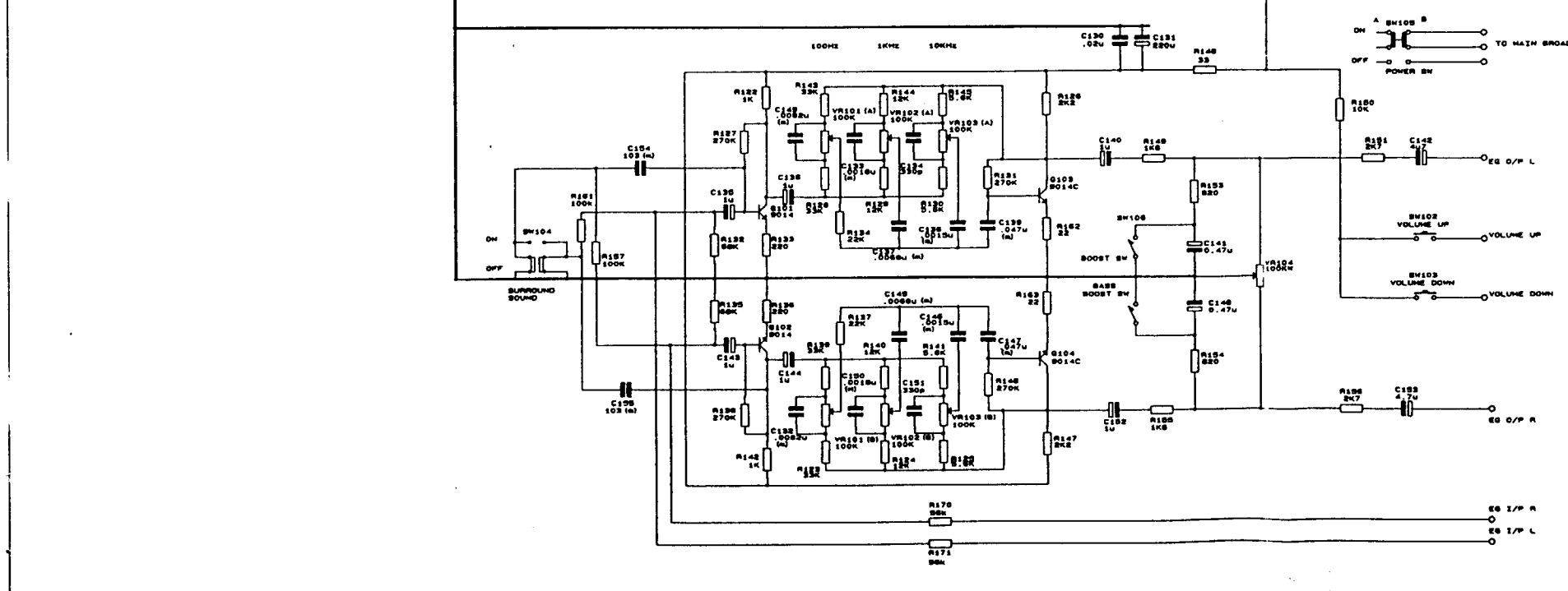
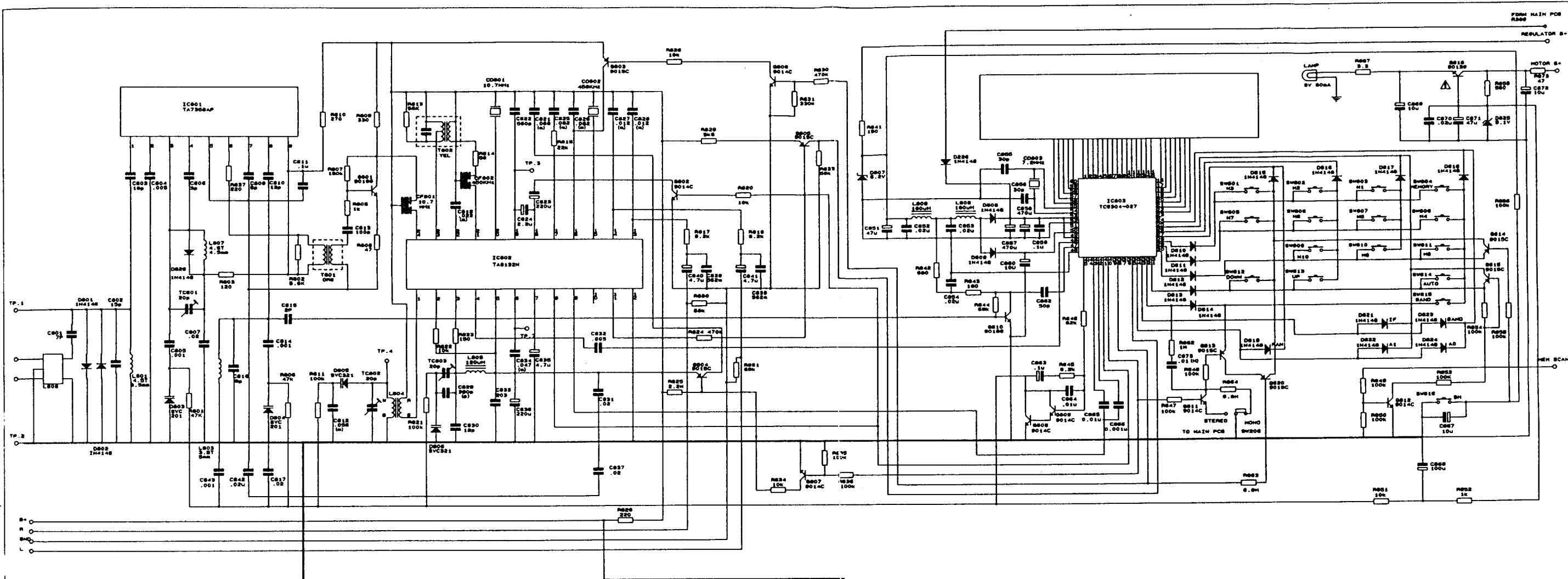

WARNING
 AFTER COMPLETING THE SERVICING OF THIS PRODUCT AND BEFORE RETURNING IT TO YOUR CUSTOMER MEASURE THE RESISTANCE BETWEEN BOTH PROBES OF THE AC PLUG AND ALL EXPOSED METAL PARTS TO BE SURE IT EXCEEDS 2.5 MEGOHMS. POWER SWITCH IF ANY SHOULD BE IN ITS ON POSITION. IF THE RESISTANCE MEASURED IS LESS THAN 2.5 MEGOHMS, THE UNIT SHOULD NOT BE RETURNED TO THE CUSTOMER UNTIL THE CAUSE FOR THE REDUCED POWER LINE TO EXPOSED METAL PARTS RESISTANCE HAS BEEN CONNECTED AND THE UNIT PASSED THE ABOVE TEST.

THIS MARK INDICATES THAT THE ADJACENT COMPONENT IS CONSIDERED CRITICAL WITH RESPECT TO THE RISK OF FIRE AND ELECTRICAL SHOCK ASSOCIATED WITH THIS PRODUCT. WHEN REPLACING ANY OF THESE COMPONENTS, USE ONLY PARTS SUPPLIED BY MANUFACTURER WHOSE PART NUMBERS ARE INDICATED ON THE PARTS LIST ATTACHED.

SERVICING INSTRUCTIONS

1. Disconnect power cord before servicing.
2. Replace critical components Δ only with factory parts or recommended equivalents.
3. For AC line powered units - Before resuming repaired unit to user, use an ohmmeter to measure from both AC plug blades to all exposed metallic parts. The resistance should be more than 100,000 ohms.

ORIENT POWER ELECTRONICS LTD.			
TITLE: SCHEMATIC DIAGRAM			
PROJECT :	OPS (CARD B)	SHEET	OF
DESCRIPTION :	RADIO 6 EG BROAD	REV.1	VER.1
CAD FILE :	110CRUCP	SIZE :	
DRN BY :	C.H.VUEH	DATE :	11-1-1993
CHK BY :		DATE :	
APPD BY :		DATE :	

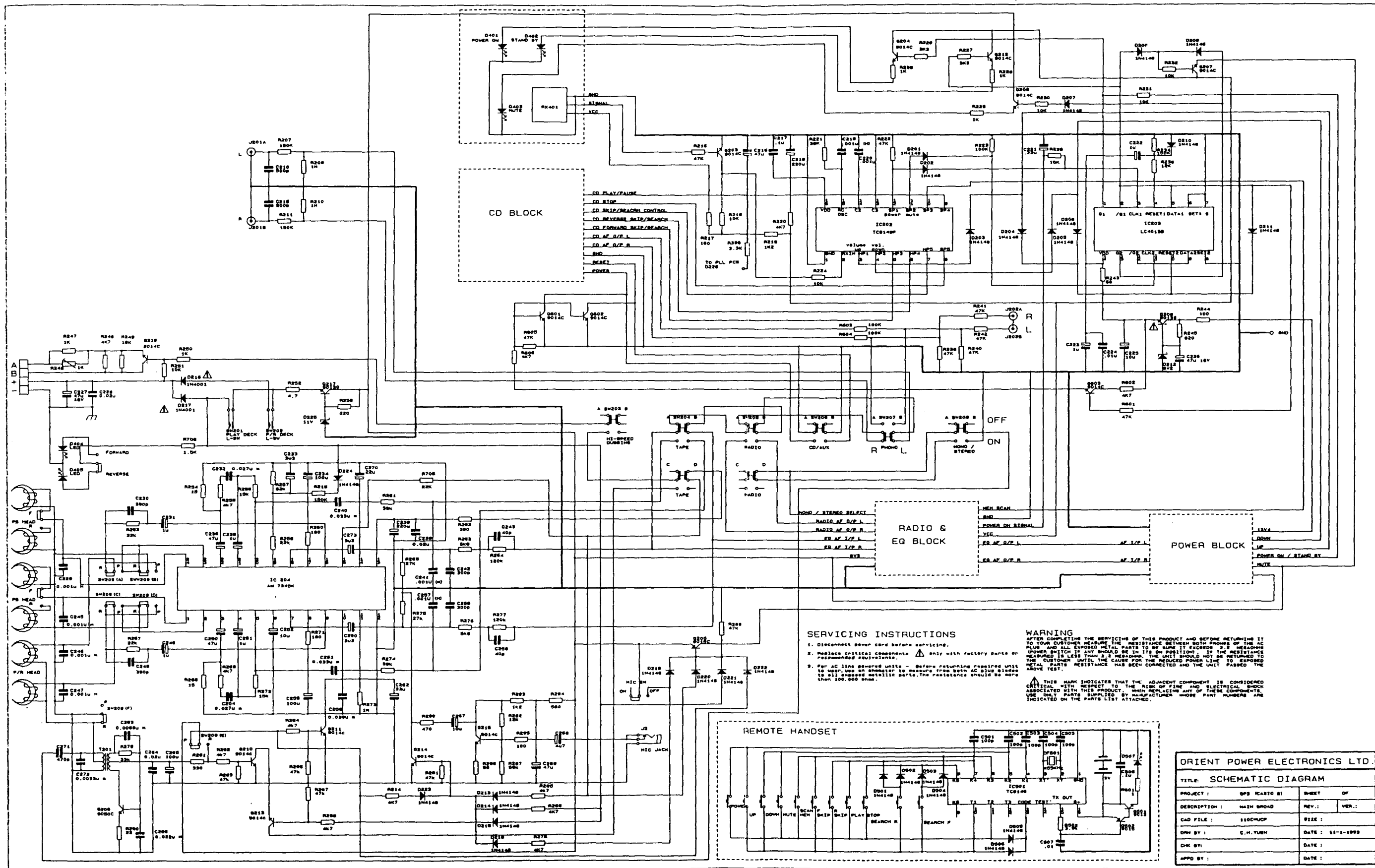

SERVICING INSTRUCTIONS

1. Disconnect power cord before servicing.
2. Replace electrical components only with factory parts or performance equivalents.
3. For AC line grounded units - Before performing repairs units to user, use an ohmmeter to measure from both AC line wires to all exposed metallic parts. The resistance should be more than 100,000 ohms.

WARNING

AFTER COMPLETING THE SERVICING OF THIS PRODUCT AND BEFORE RETURNING IT TO YOUR CUSTOMER MEASURE THE RESISTANCE BETWEEN BOTH PHASES OF THE AC PLUG AND ALL EXPOSED METAL PARTS TO BE SURE IT EXCEEDS 2.5 MEGOHMS. IF THE RESISTANCE MEASURED IS LESS THAN 2.5 MEGOHMS, THE UNIT SHOULD NOT BE RETURNED TO THE CUSTOMER UNTIL THE CAUSE FOR THE REDUCED POWER LINE TO EXPOSED METAL PARTS RESISTANCE HAS BEEN CORRECTED AND THE UNIT PASSED THE ABOVE TEST.

THIS MARK INDICATES THAT THE ADJACENT COMPONENT IS CONSIDERED CRITICAL WITH RESPECT TO THE RISK OF FIRE AND ELECTRICAL SHOCK ASSOCIATED WITH THIS PRODUCT. WHEN REPLACING ANY OF THESE COMPONENTS, USE ONLY PARTS SUPPLIED BY MANUFACTURER WHOSE PART NUMBERS ARE INDICATED ON THE PARTS LIST ATTACHED.

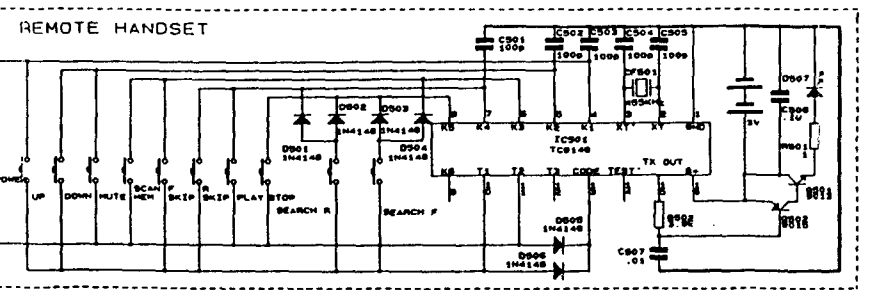

ORIENT POWER ELECTRONICS LTD.			
TITLE: SCHEMATIC DIAGRAM			
PROJECT:	OPS RADIO 81	SHEET:	OF
DESCRIPTION:	MAIN BOARD	REV.:	VER.:
CAD FILE:	110CMUP	SIZE:	
DWG BY:	C.H. YUEN	DATE:	11-1-1998
CHK BY:		DATE:	
APPD BY:		DATE:	

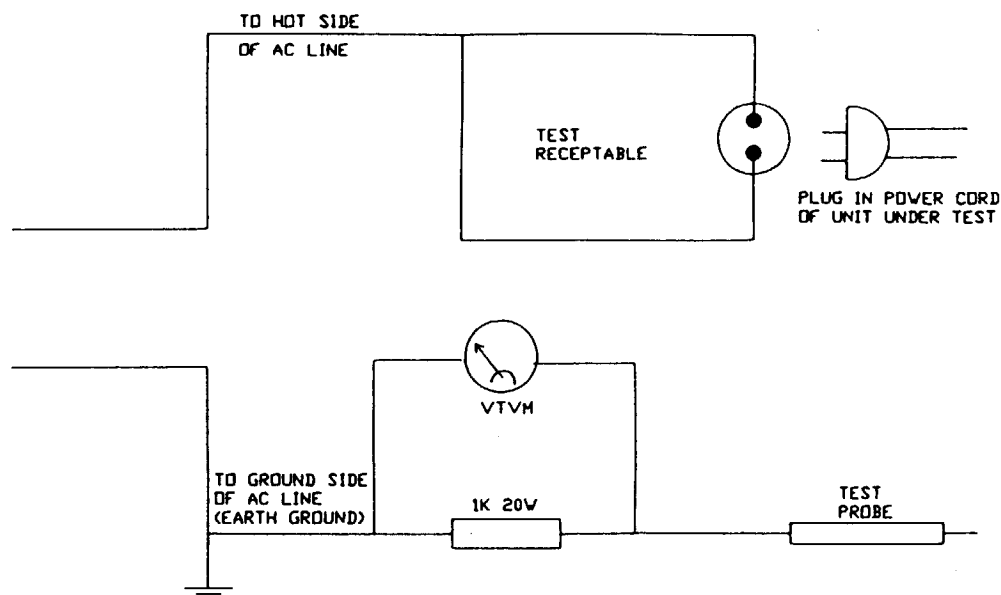

FIGURE 1 SAFETY TEST CIRCUIT

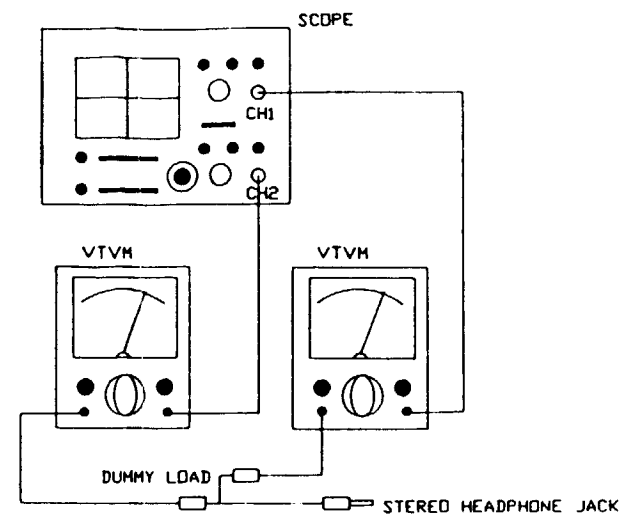

FIGURE 2 AZIMUTH ADJUSTMENT

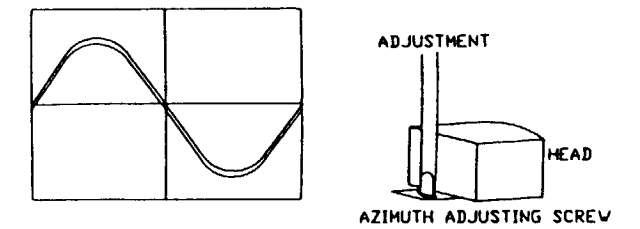

FIGURE 3 HEAD OUTPUT SIGNAL

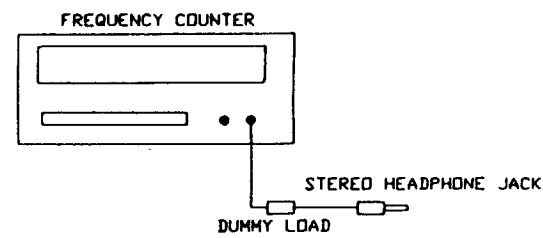

FIGURE 4 TAPE SPEED ADJUSTMENT

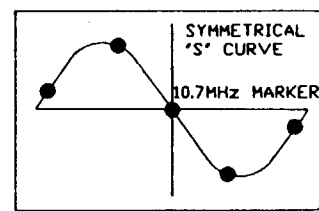

FIGURE 6 'S' CURVE

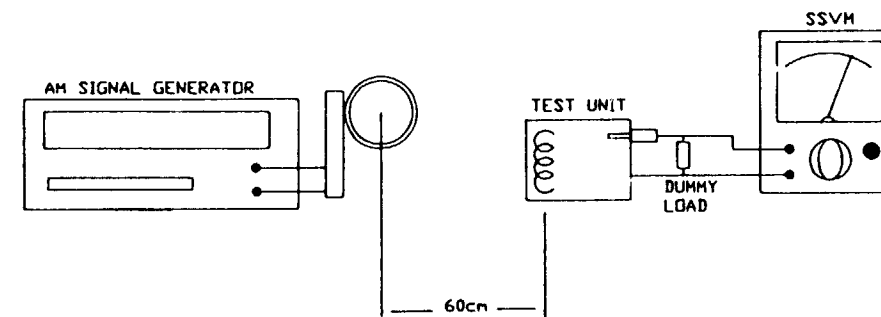

FIGURE 7 AM IF/RF TRACKING

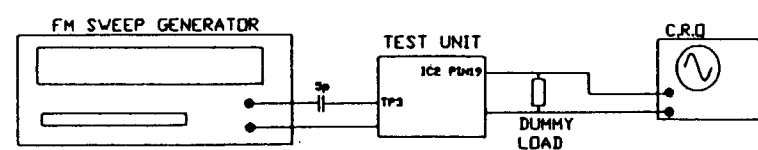

FIGURE 8 FM IF ALIGNMENT

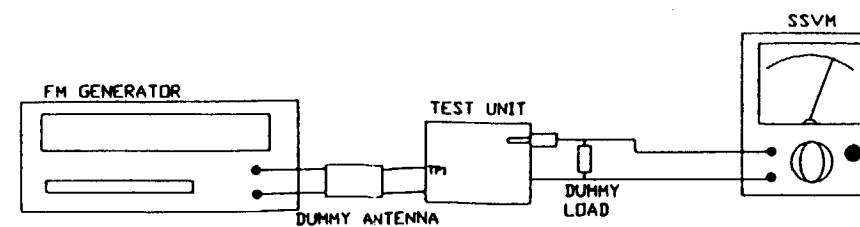

FIGURE 9 FM BAND/TRACKING

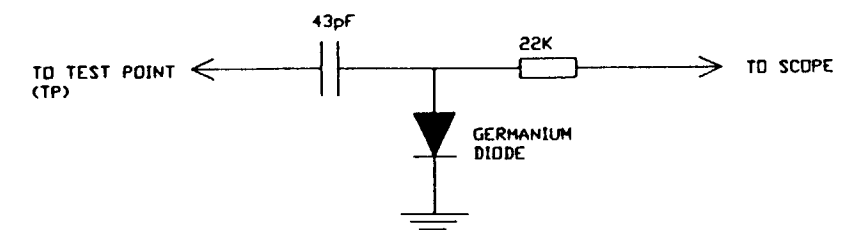
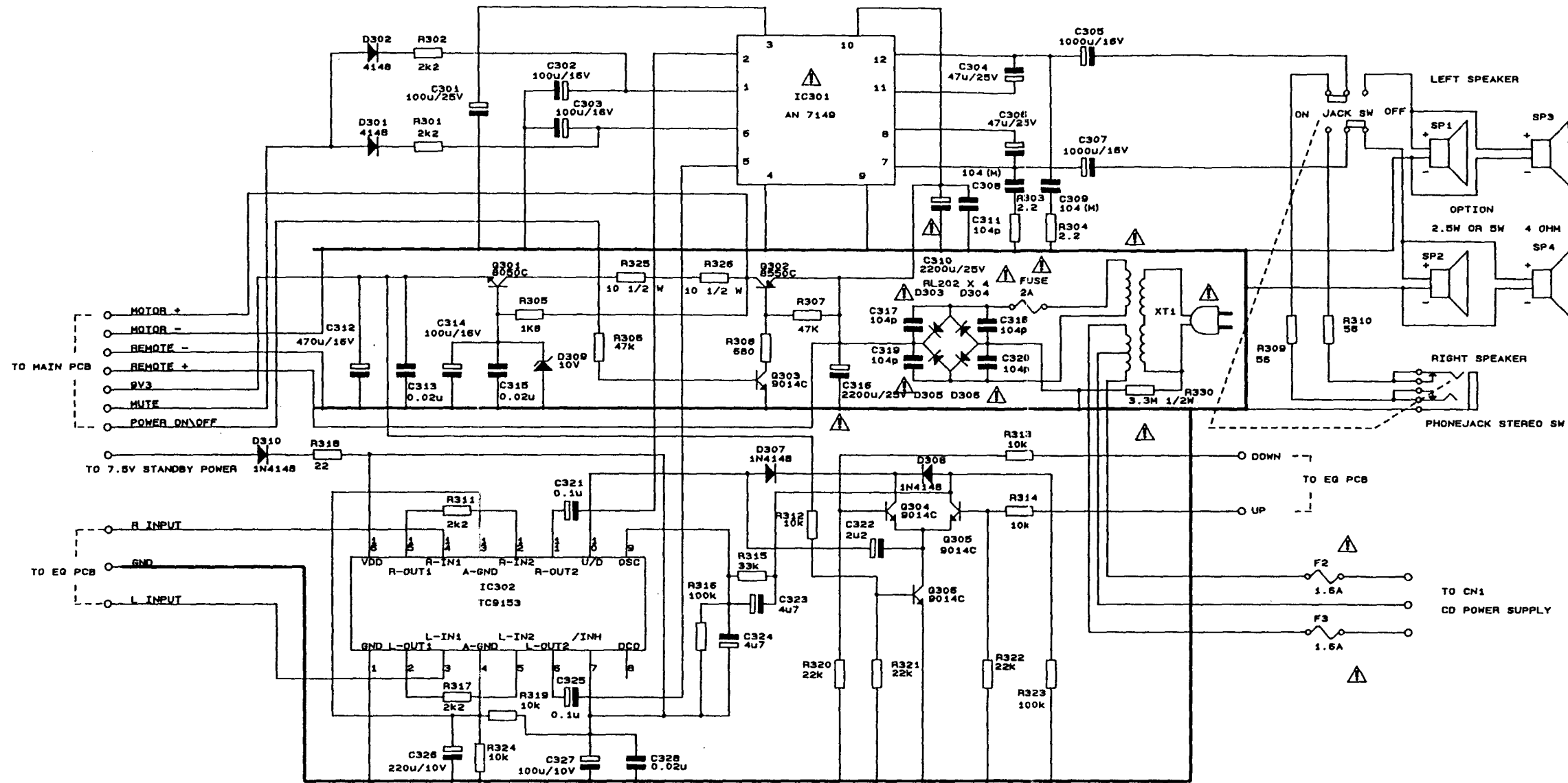

FIGURE 10 ALIGNMENT PAD #1



WARNING

AFTER COMPLETING THE SERVICING OF THIS PRODUCT AND BEFORE RETURNING IT TO YOUR CUSTOMER MEASURE THE RESISTANCE BETWEEN BOTH PRONGS OF THE AC PLUG AND ALL EXPOSED METAL PARTS TO BE SURE IT EXCEEDS 2.2 MEGOHMS (POWER SWITCH IF ANY SHOULD BE IN ITS ON POSITION). IF THE RESISTANCE MEASURED IS LESS THAN 2.2 MEGOHMS, THE UNIT SHOULD NOT BE RETURNED TO THE CUSTOMER UNTIL THE CAUSE FOR THE REDUCED POWER LINE TO EXPOSED METAL PARTS RESISTANCE HAS BEEN CORRECTED AND THE UNIT PASSED THE ABOVE TEST.

THIS MARK INDICATES THAT THE ADJACENT COMPONENT IS CONSIDERED CRITICAL WITH RESPECT TO THE RISK OF FIRE AND ELECTRICAL SHOCK ASSOCIATED WITH THIS PRODUCT. WHEN REPLACING ANY OF THESE COMPONENTS, USE ONLY PARTS SUPPLIED BY MANUFACTURER WHOSE PART NUMBERS ARE INDICATED ON THE PARTS LIST ATTACHED.

SERVICING INSTRUCTIONS

1. Disconnect power cord before servicing.
2. Replace critical components  only with factory parts or recommended equivalents.
3. For AC line powered units - Before returning repaired unit to user, use an ohmmeter to measure from both AC plug blades to all exposed metallic parts. The resistance should be more than 100,000 ohms.

ORIENT POWER ELECTRONICS LTD.			
TITLE: SCHEMATIC DIAGRAM			
PROJECT :	OP3 (CASIO B)	SHEET	OF
DESCRIPTION :	POWER BROAD	REV.:	VER.:
CAD FILE :	110CPUCP	SIZE :	
DRW BY :	C.H.YUEN	DATE :	11-1-1993
CHK BY :		DATE :	
APPD BY :		DATE :	